

Technical data sheet

Product features



Multi-function fixed braising pan bowl electric 40

Model	SAP Code	00013570
--------------	-----------------	----------



- Bottom material: Stainless steel - suitable for cooking, easy maintenance
- Bottom thickness: 16.00
- Basin volume [l]: 16
- Protection of controls: IPX5
- Basin dimensions [mm x mm x mm]: 300 x 680 x 100
- Service accessibility: Trough the frontal panel

SAP Code	00013570	Power electric [kW]	5.200
Net Width [mm]	400	Loading	400 V / 3N - 50 Hz
Net Depth [mm]	800	Bottom material	Stainless steel - suitable for cooking, easy maintenance
Net Height [mm]	280	Basin volume [l]	16
Net Weight [kg]	50.00		

Technical data sheet

Technical drawing



Multi-function fixed braising pan bowl electric 40

Model	SAP Code	00013570
--------------	-----------------	----------

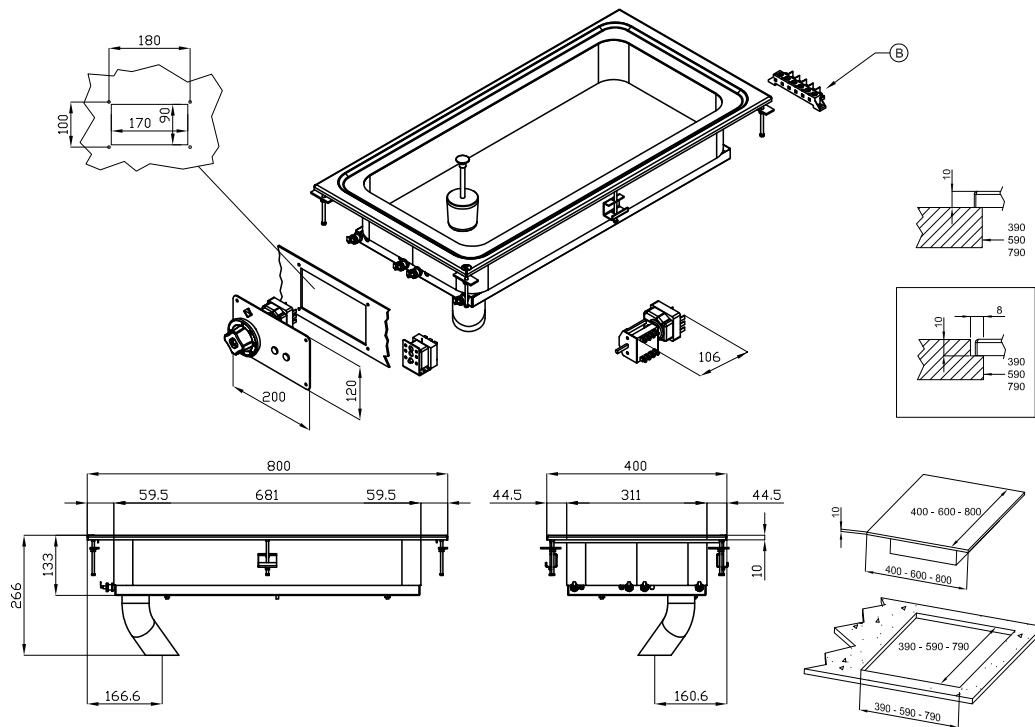

A	Data plate		B	Electrical connection	
---	------------	--	---	-----------------------	--

Technical data sheet

Technical parameters



Multi-function fixed braising pan bowl electric 40

Model

SAP Code

00013570

1. SAP Code:

00013570

2. Net Width [mm]:

400

3. Net Depth [mm]:

800

4. Net Height [mm]:

280

5. Net Weight [kg]:

50.00

6. Gross Width [mm]:

430

7. Gross depth [mm]:

970

8. Gross Height [mm]:

540

9. Gross Weight [kg]:

60.00

10. Device type:

Electric unit

11. Construction type of device:

Drop-in

12. Power electric [kW]:

5.200

13. Loading:

400 V / 3N - 50 Hz

14. Protection of controls:

IPX5

15. Material:

AISI 304

16. Indicators:

operation and warm-up

17. Basin volume [l]:

16

18. Basin dimensions [mm x mm x mm]:

300 x 680 x 100

19. Maximum device temperature [°C]:

300

20. Minimum device temperature [°C]:

50

21. Power control type:

knob control

22. Service accessibility:

Trough the frontal panel

23. Bottom thickness:

16.00

24. Bottom material:

Stainless steel - suitable for cooking, easy maintenance

25. Drain:

Yes